

AUTOMATIC DIE-CUTTER

SHEET FED CREAMING,
DIE-CUTTING AND
KISS-CUTTING WITH
HIGH-CAPACITY FEEDER

SC5000 Auto Sheet Cutter



Fully automated, sheet cutting production Packaging, P.O.S. and labels



Flawless auto-feeding and faultless digital cut-through operation of any shape on up to 350 micron media, with the dual tool head delivering up to 750g of force per tool



Articulated control module



POWERED BY
ColorCut Pro

A revolutionary new type of automated cutter - blending flatbed and sheet fed technologies!

Perfect for digitally die-cutting packaging, P.O.S. and lightweight card projects – as well as kiss-cutting sheet labels – the all new ColorCut SC5000 is an 'on demand' digital sheet cutter with no physical dies or time-consuming setup costs.

Targeted for busy print departments, seeking an affordable, high-capacity device for complete unattended cutting production, the SC5000 combines ultra-reliable feeding with an instant job retrieval system and flawless high-speed cutting and creasing. This compact free-standing device is conveniently mobile and will be easily accommodated in any print shop.

Complete standalone operation - even with a stack of mixed jobs

- 8th generation Vision3 CCD camera reads and instantly retrieves cut files for every sheet on the fly! Accepts a mixed stack of jobs, cutting one after the other in a seamless and uninterrupted flow.
- Dual 'Grip and Drive' feed system holds media during cutting on both sides of the cutting head, enabling it to cut closer to media edges.
- Revolutionary cutting strip, based on the superior cutting mats used in Intec flatbeds, delivers an optimal surface for both cut-through, creasing and kiss-cut.
- SmartTags are left in the cut lines to retain the item in the sheet - leaving a tidy and manageable stack of finished complete sheets in the catch tray.
- High-capacity auto feeder works in conjunction with air blade separation and automated jog function, to present every sheet perfectly for the cutter, every time.
- ColorCut Pro Production Studio software is supplied as standard and offers remarkable digital productivity for the designer and machine operator alike.



Market-leading features

- Digitally cut-through any shape sheet card item - with SmartTag retention - on up to 350 micron media, or kiss-cut sheet labels - all at up to 37.79"/sec
- Digital process means no more costly dies or wasted waiting time
- Auto feeder stacks up to 900 sheets. Up to 13.38" (340mm) x 20.47" (520mm) and custom sizes - with self centring function and air blade/ite separation
- ColorCut Pro - Production Studio software included
- QR* code/Job Library retrieves associated cut files - even for mixed job batch sessions or rotated sheets
- SmartMark registration delivers incredible accuracy - enabled via included ColorCut Pro software

PRODUCT ON
WEBSITE



WATCH
VIDEO



Optional ColorCut Pro Server Station seriously enhances productivity. Supplied complete with a pre-installed Windows® PC and ColorCut Pro software suite, with a flat screen monitor, mouse and keyboard. Also includes software User Licence for two additional seats.



*QR codes and SmartMarks are generated as part of the included ColorCut Pro software plugin which integrates with vector artwork created in Adobe® Illustrator® and CoreDRAW®



colorCUT Sheet Label Cutting



Huge 900 sheet capacity stacker/feeder

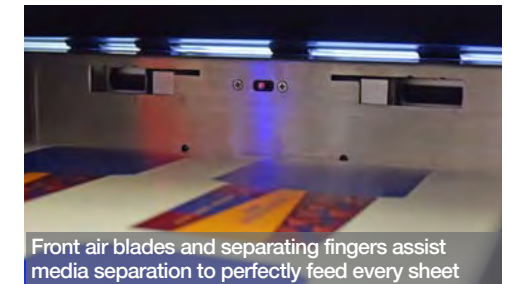

Front air blades and separating fingers assist media separation to perfectly feed every sheet

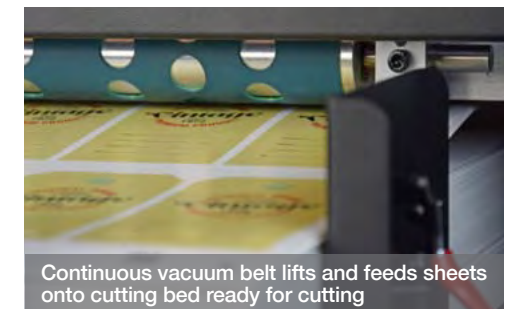

Continuous vacuum belt lifts and feeds sheets onto cutting bed ready for cutting

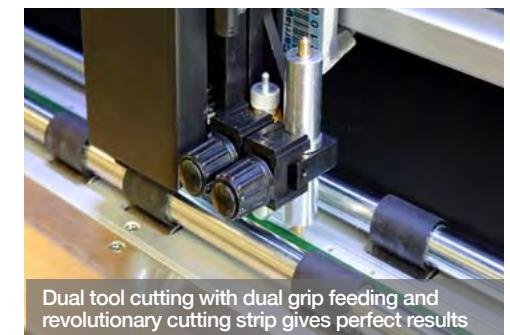

Dual tool cutting with dual grip feeding and revolutionary cutting strip gives perfect results



Space-saving, retractable media catch tray

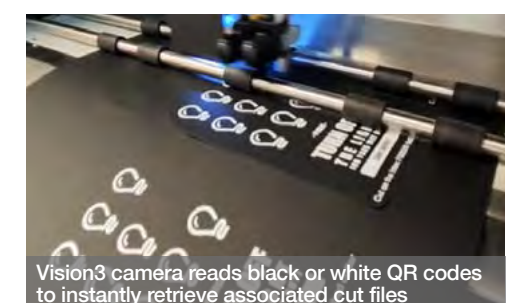

Vision3 camera reads black or white QR codes to instantly retrieve associated cut files

colorCUT

High-capacity and ultra-reliable feeding

The SC5000 has been designed to provide unattended operation with particular attention paid to the feeding system to ensure class-leading performance for card, vinyl labels or even tricky laminated sheets. The SC5000's auto feeder accepts up to 900 sheets, which automatically raises and lowers as required. To prevent sheets curling, as a result of a constant air flow to the sides, the SC5000's uses an automatic air blade that fires a blast of air momentarily into the front of the stack just as the advanced vacuum feed belt lowers to collect the top sheet using pneumatic suction. To further provide a reliable feed, the vacuum feed belt lifts the media carrying any sheets not pre-separated by the air blade past a pair of dexterous separation fingers which dislodges them. Finally before advancing the sheet into the cutting engine, the vacuum feed belt 'jogs' briefly against the rear paper stop, creating a natural curve that helps ensure even difficult media feeds faultlessly.

Dual tool power - digital accuracy

The digital cutting head can apply up to 750g of force, individually for both the cutting and creasing tools. Their actions are controlled via the included ColorCut Pro software. In common with the entire ColorCut family, the SC5000 can be set to apply exact amounts of pressure and speed, along with total control over the application of cut, crease and perforation of the vector artwork lines.

Ergonomic, compact and mobile

The space-saving media catch tray slides away when not in use and the manoeuvrable stand ensures it is easily accommodated into any environment.

The 5 inch immersive touch screen control panel is housed within an articulated module which can pivot to suit the angle desired by the operator.

Easy to use automatic job retrieval

When creating jobs, ColorCut Pro applies an auto assigned (editable) QR code* to each design, whilst auto-saving the cutting file to the ColorCut Pro Job Library.

Jobs with QR codes can be cut at a later date by any operator - no need to search for which file to cut - no specific computer application skills required! The SC5000 checks the QR code on each sheet, retrieves the associated cut file and proceeds to cut and crease as required - even if the sheet is presented at 180°.

Choose to cut a single sheet or even thousands on an unattended run.

The Vision3 CCD camera has an 8th generation sensor with enhanced sensitivity to read even white QR codes and SmartMarks, when applied on dark media.

Latest 8th generation CCD camera reads positive and inverted QR codes and SmartMarks, handling mixed jobs to maintain perfect cut accuracy

Specifications



Intec ColorCut SC5000 Auto Sheet Cutter

MEDIA HANDLING									
Standard media sizes	Letter, legal, tabloid, ledger, tabloid extra and custom								
Custom sized label media	Media width (min-max): 7.08" x 13.38" Media length (min-max): 10.98"x 20.47"								
Media thickness	0.14mm (140 micron) - 0.35mm (350 micron)								
Auto-sheet capacity	3.34" stacker height or 33.06 (Up to 900 sheets for auto-sheet feed, based on 80gsm media)								
Media alignment	Self-centring guides - lockable								
CUTTING CONTROL									
Mountable tools (dual tool holder)	Blade holder - holds cutting blades; 30°, 45° or 60° for range of media types Creasing tool - dual ended (wide & narrow) suitable for ≤350 micron card Calibration pen - pen, plotting pen used for auto-calibration. Can be used in either mountable location								
Cutting blades	<table border="1"> <tr> <td>Yellow</td> <td>1mm 30° cemented carbide blade - for thin film and very soft material</td> </tr> <tr> <td>Red</td> <td>1mm 45° cemented carbide blade - for thin card up to 0.35mm and adhesive stickers</td> </tr> <tr> <td>Blue</td> <td>1mm 60° cemented carbide blade - for thick vinyl media, sharply angled tip provides a longer cutting edge</td> </tr> <tr> <td>Red</td> <td>1.5mm 45° industrial cutting blade for card based projects up to 350 micron</td> </tr> </table>	Yellow	1mm 30° cemented carbide blade - for thin film and very soft material	Red	1mm 45° cemented carbide blade - for thin card up to 0.35mm and adhesive stickers	Blue	1mm 60° cemented carbide blade - for thick vinyl media, sharply angled tip provides a longer cutting edge	Red	1.5mm 45° industrial cutting blade for card based projects up to 350 micron
Yellow	1mm 30° cemented carbide blade - for thin film and very soft material								
Red	1mm 45° cemented carbide blade - for thin card up to 0.35mm and adhesive stickers								
Blue	1mm 60° cemented carbide blade - for thick vinyl media, sharply angled tip provides a longer cutting edge								
Red	1.5mm 45° industrial cutting blade for card based projects up to 350 micron								
Cutting system (force)	Contour cutter, with up to 7.60N (750gf) delivered in 190 steps programmable through Intec ColorCut Pro cutting software								
Mechanical / Programme resolution	0.01254mm / HPGL 0.025mm								
Maximum speed	960mm/s								
SOFTWARE & CONNECTIVITY									
ColorCut Pro 3 – Plugin (PC)	ColorCut Pro 3 plug-in (all features available). ColorCut Pro sends projects designed in Adobe® Illustrator® or CorelDRAW® directly to Intec ColorCut label cutter with no need to convert them to a different format. Requires: PC - Adobe® Illustrator® CS1 – CS6, CC, CC2014 - CC2021, or CorelDRAW® X4 - X8, 2017 - 2021								
ColorCut Pro 3 – Plugin (Mac)	ColorCut Pro 3 Plugin for Mac enables the ColorCut Pro Job Library Client. Mac users add cut marks automatically to Illustrator files and assign Job numbers and QR codes. The jobs are sent to the remote ColorCut Pro Job Library on a PC for cutting. Requires: Illustrator CC2018- 2021								
ColorCut Pro 3 – Standalone	ColorCut Pro – Job Server version of ColorCut Pro is PC only and enables jobs created by the ColorCut Pro plugin (above) to be cut at any time, without requiring Adobe® Illustrator® or CorelDRAW® and without having to re-open the original file								
PC minimum specification	64-bit. 2 GB of RAM (4 GB recommended). Minimum display resolution: 960x830. For live preview PC must have Wi-Fi capability for direct connection to Vision3 CCD camera (USB Wi-Fi dongle included)								
Connectivity	USB (1 connection to PC is required)								
REGISTRATION CONTROL & JOB MANAGEMENT									
Registration system	Vision3 - High resolution CCD vision system reads the registration marks on the media, comparing position with original digital file. Automatically adjusting cut lines to correct any scale or skew positional differences								
Cut position accuracy	+/- 100 micron								
Auto job recognition	Yes: Instant cut file retrieval, supported through QR code job recognition in conjunction with ColorCut Pro 3 software (supplied)								
Varied or mixed job recognition	Yes								
POWER REQUIREMENTS									
Voltage	AC 110-240v~, 50-60Hz, 180w,								
Power supply	180w, 6.8A (110-220v), 3.4A (200-240v)								
Approvals	Complies with CE and RoHs directive								
GENERAL									
Weight (unpacked) including stand	115kgs								
Power supply	AC 110-220V 50/60Hz, 0.5A								
Dimensions W x D x H	790 x 680 x 1270mm (31 x 27 x 50 inches)								
Max' area required in use on stand	790x 1135 x 1270mm (31 x 45 x 50 inches)								

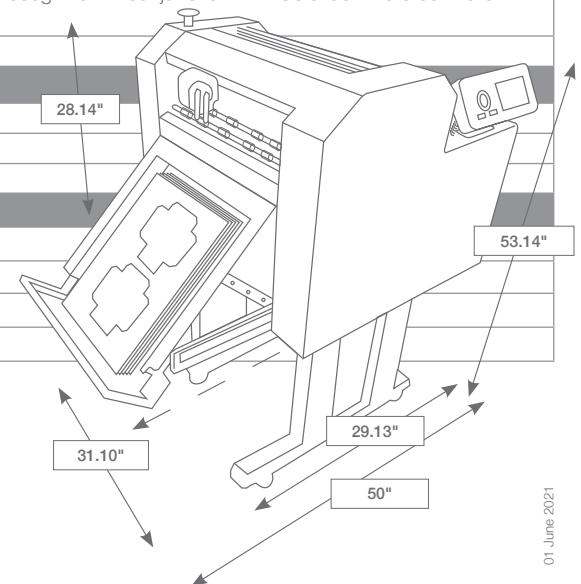

Intec Printing Solutions Corporation
 16011 N. Nebraska Avenue,
 Lutz, FL 33549 USA
 Tel: +1 813-949-7799 Fax: +1 813-949-7886
www.intecprinters.com